

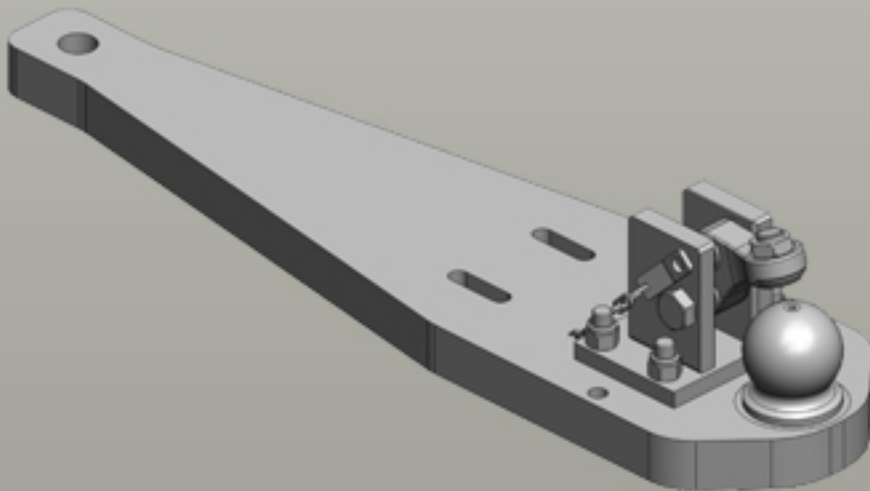

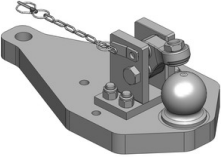



Heavy Duty Drawbars Claas | Arion 400 (A72/A73)

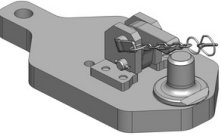

Heavy Duty Drawbars

	<p>Art.Nr. 00.960.649.0-A11 Heavy Duty Drawbars Standard K80® Ball Coupling System </p> <ul style="list-style-type: none"> fits to Scharmüller Ladder-Hitch with Drawbar Frame <p>Alternative color </p> <p>00.960.649.0-A11 (AGCO-Grey)</p> <p>Technical Values*</p> <p>Length (mm): 480 Wide (mm): 256 Assembly-Positions: 1 Thickness (mm): 40 Locking: K80® Manual Max. Permissible D-Value (kN): 59,8 Max. Permissible Vertical Load (kg): 3000</p> <p>Adapted for Tractor</p> <p>Claas: Arion 400 (A32/A43): 410, 420, 430, 440, 450, 460; Arion 400 (A72/A73): 410, 420, 430, 440, 450, 460; Massey Ferguson: 4700: 4707, 4708, 4709; 5400: 5410, 5420, 5430, 5440, 5450; 5600 Dyna-4: 5608, 5609, 5610, 5611, 5612, 5613; 5700(SL) Dyna-4/6: 5710, 5711, 5712, 5713; Valtra: A4-Series: 104, 114, 124, 134, 74, 84, 94; G-Series: 105, 115, 125, 135;</p>
	<p>Art.Nr. 00.961.171.5-A11 Heavy Duty Drawbars Standard Draw-Pin (Pitonfix) </p> <ul style="list-style-type: none"> fits to Scharmüller Ladder-Hitch with Drawbar Frame <p>Alternative color </p> <p>00.961.171.5-A11 (AGCO-Grey)</p> <p>Technical Values*</p> <p>Length (mm): 445 Wide (mm): 220 Assembly-Positions: 1 Thickness (mm): 40 Locking: Draw Pin (Pitonfix) Manual Max. Permissible D-Value (kN): 71,9 Max. Permissible Vertical Load (kg): 3000</p> <p>Adapted for Tractor</p> <p>Claas: Arion 400 (A32/A43): 410, 420, 430, 440, 450, 460; Arion 400 (A72/A73): 410, 420, 430, 440, 450, 460; Massey Ferguson: 4700: 4707, 4708, 4709; 5400: 5410, 5420, 5430, 5440, 5450; 5600 Dyna-4: 5608, 5609, 5610, 5611, 5612, 5613; 5700(SL) Dyna-4/6: 5710, 5711, 5712, 5713; Valtra: A4-Series: 104, 114, 124, 134, 74, 84, 94; G-Series: 105, 115, 125, 135;</p>